

KLINGER Durchgangsventil / piston valve KVN 2 1/2" - 8" VIII-KX-GT

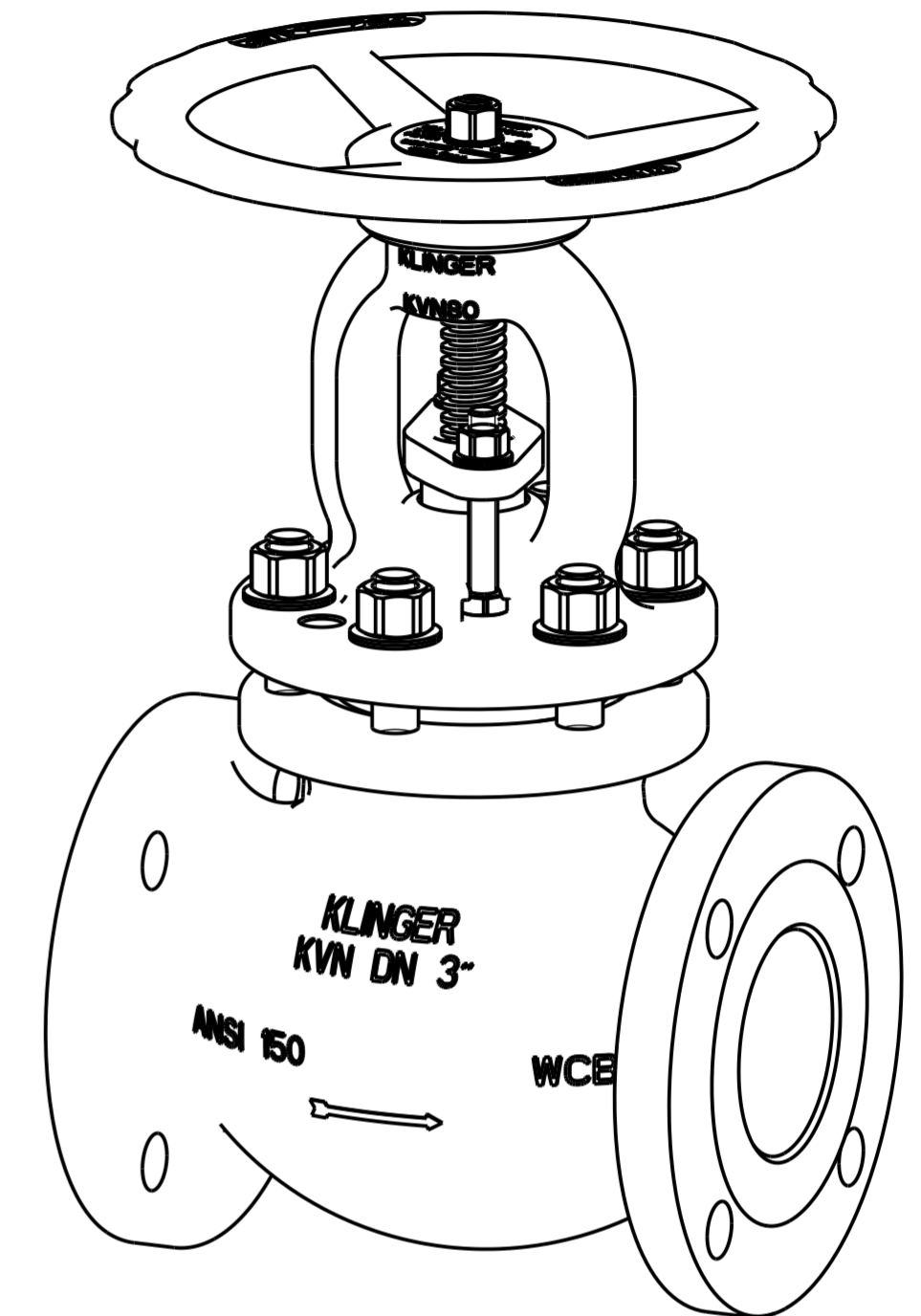
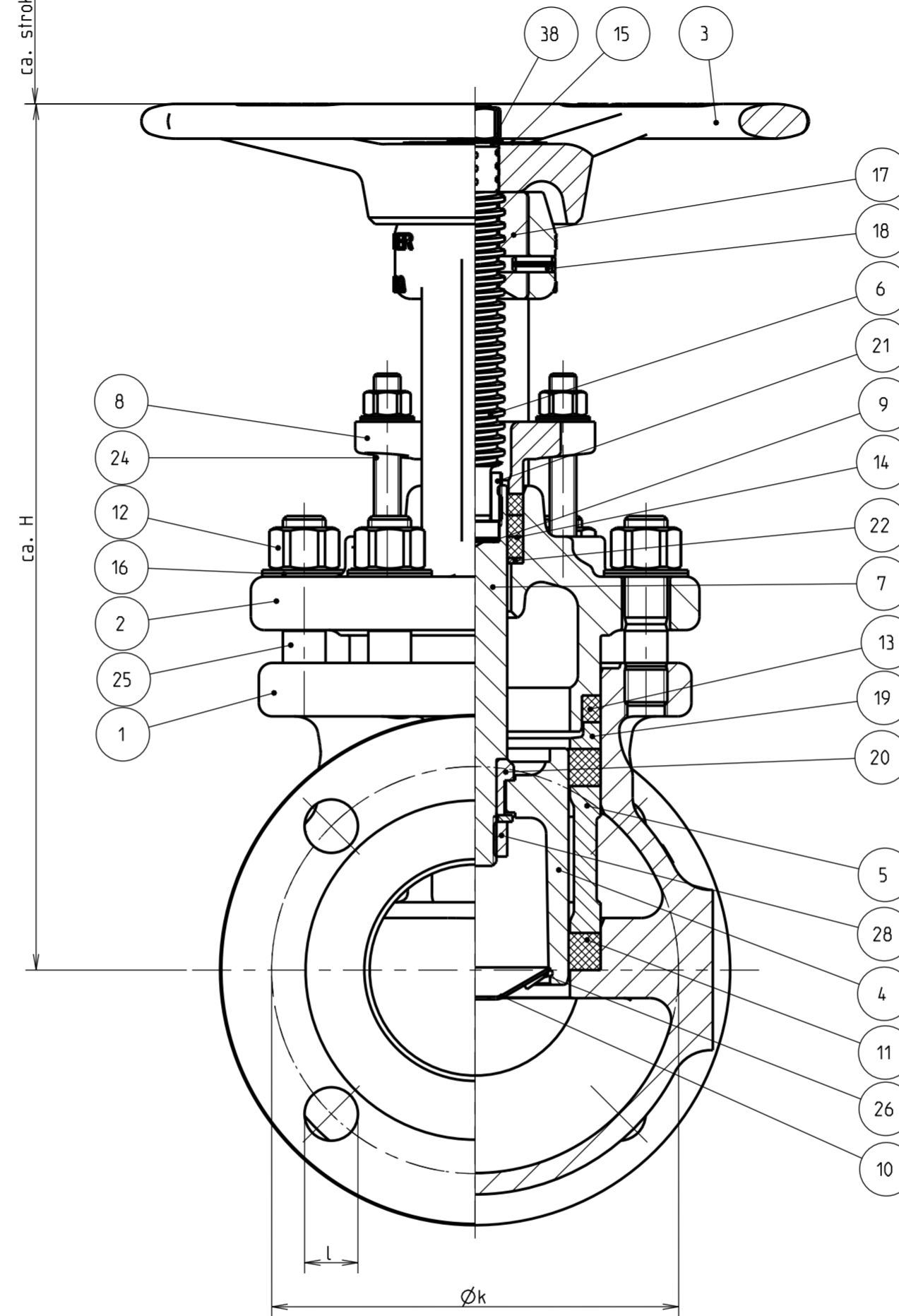
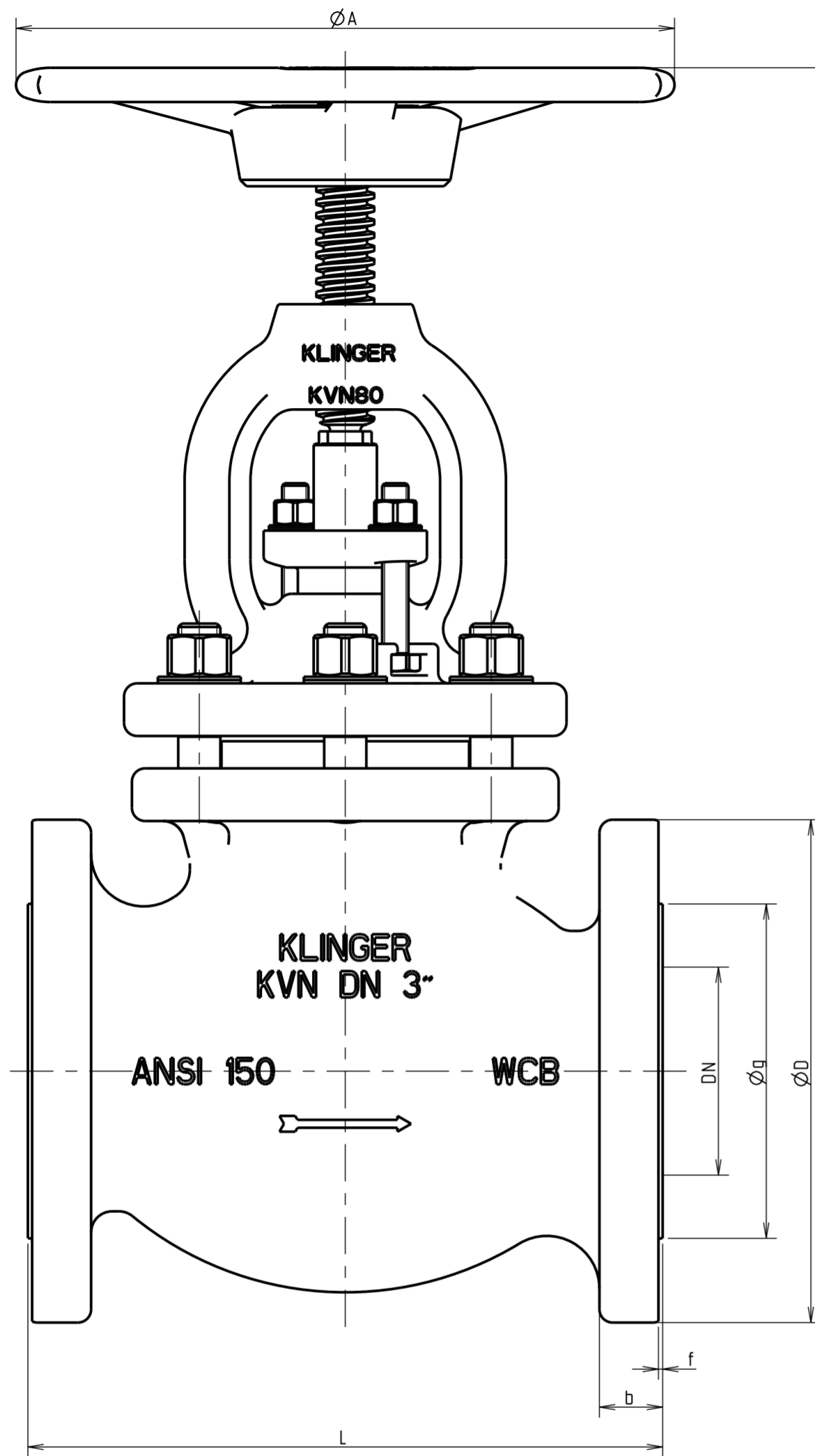

DN...Nenngröße der Armatur
GG...Gesamtgewicht [kg]
n....Anzahl der Bohrungen

DN...nominal valve size
GG...valve weight [kg]
n....number of holes

| DN | Class | L | H | $\varnothing A$ | $\varnothing D$ | $\varnothing g$ | b | f | $\varnothing k$ | l | n | stroke | GG | | | | |
|--------|-------|-----|-----|-----------------|-----------------|-----------------|-------|-----|-----------------|-----|-----|--------|------------------|-------------------------|---------------|--------|--------|
| 2 1/2" | 150 | 216 | 306 | 250 | 178 | 105 | 22 | 1.6 | 139.7 | 20 | 4 | 47 | 26 | | | | |
| 3" | | 241 | 324 | 191 | 127 | 24 | 152.4 | | 34 | | | | | | | | |
| 4" | | 292 | 370 | 280 | 229 | 157 | 24.5 | | 190.5 | | | 51 | 7 | | | | |
| 6" | | 406 | 475 | 280 | 215.9 | 26.5 | 241.3 | | 105 | | | 6 | | | | | |
| 8" | 495 | 560 | 400 | 345 | 269.8 | 29 | 298.5 | 180 | 5 | 116 | 180 | 5 | Laterne KVN 80 | Lantern bush | EN-GJL-200 | | |
| 2 1/2" | 300 | 292 | 306 | 250 | 191 | 105 | 26 | 1.6 | 149.4 | 22 | 8 | 47 | 29 | 4 | Kolben KVN 80 | Piston | 1.4308 |
| 3" | | 318 | 324 | 217 | 127 | 29.5 | 168.1 | | 41 | | | 3 | Handrad KVN DN65 | Handwheel | EN-GJL-200 | | |
| 4" | | 365 | 370 | 280 | 254 | 157 | 32.5 | | 200.1 | | | 60 | 2 | Oberteil KVN 80 PN40 | Bonnet | 1.0619 | |
| 6" | | 445 | 475 | 400 | 318 | 215.9 | 38 | | 269.8 | | | 113 | 1 | Gehäuse KVN 3" Class150 | Body | WCB | |
| 8" | 559 | 560 | 381 | 269.9 | 41.5 | 330.2 | 26 | 12 | 116 | 195 | 116 | 195 | Pos. | Name | Material | | |

| | | | |
|------|----------------------------|-------------------|------------|
| 38 | Fächerscheibe | Hex nut | 1.1181 |
| 28 | Sechskantmutter gekerbt | Hex nut | 5 |
| 26 | Drahttring | Hex nut | 1.1181 |
| 25 | Stiftschraube | Securing ring | 1.4310 K |
| 24 | Sechskantschraube | Stud bolt | 1.7709 |
| 22 | Einlegtring | Hex head screw | 8.8 |
| 21 | Zweiteilige Verschraubung | Disc | A4 |
| 20 | Kolbenkegel | Washer | S12 03 |
| 19 | Druckstück | Split nut | 1.4571 |
| 18 | Spannstift | Back seat | 1.4104 |
| 17 | Gewindebuchse | Thrust piece | 1.0553 |
| 16 | Tellerfeder | Tension pin | Federstahl |
| 15 | Typenschild Halbfertigteil | Threaded bush | SINT C11 |
| 14 | Stopfbüchsenring KVN65+80 | Type plate | Al |
| 13 | Oberteil-Ventilring | Stuffing box ring | Grafit-GT |
| 12 | Sechskantmutter | OT valve ring | Grafit |
| 11 | Ventilring KVN 80 | Valve ring | Grafit-GT |
| 10 | Lenkboden KVN 65 - 200 | Piston nose cone | 1.4401 |
| 9 | Scheibe | Disc | 1.4401 |
| 8 | Brille KVN 65 | Gland retainer | EN-JS1030 |
| 7 | Kolbenschaft | Piston shaft | 1.4104 |
| 6 | Spindel | Spindle | 1.4021 |
| 5 | Laterne KVN 80 | Lantern bush | EN-GJL-200 |
| 4 | Kolben KVN 80 | Piston | 1.4308 |
| 3 | Handrad KVN DN65 | Handwheel | EN-GJL-200 |
| 2 | Oberteil KVN 80 PN40 | Bonnet | 1.0619 |
| 1 | Gehäuse KVN 3" Class150 | Body | WCB |
| Pos. | Name | Material | |

Gez. :25.04.19 Jeitler

wOV2115